

Discontinued

Panasonic
ideas for life

COMPACT, LOW-PROFILE BATTERY SOCKET WITH BELLOWS CONTACT CONSTRUCTION FOR SUPERIOR ANTI-VIBRATION AND ANTI-SHOCK PROPERTIES

BATTERY SOCKETS



FEATURES

1. Increased reliability through construction that prevents deformation when the contact is pulled up and pushed down.

1) When contact is pulled up

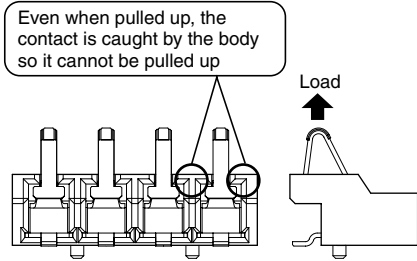

2) When contact is pushed down

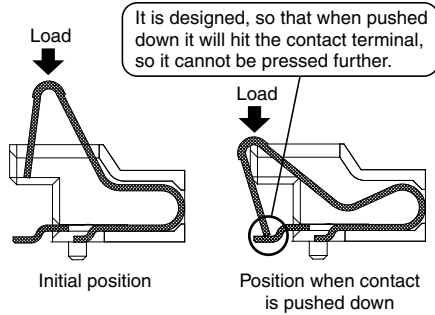

2. Support for battery mounting from the top and by sliding it horizontally.

Battery mounting direction ↓ ←

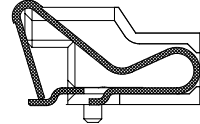

3. Bellows contact construction for shock resistance and superior contact reliability.

APPLICATIONS

Power supply connector (battery connector of mobile phones, PDAs, DSCs and laptop PC, etc., and for the connection of all types of battery chargers)

Compliance with RoHS Directive

ORDERING INFORMATION

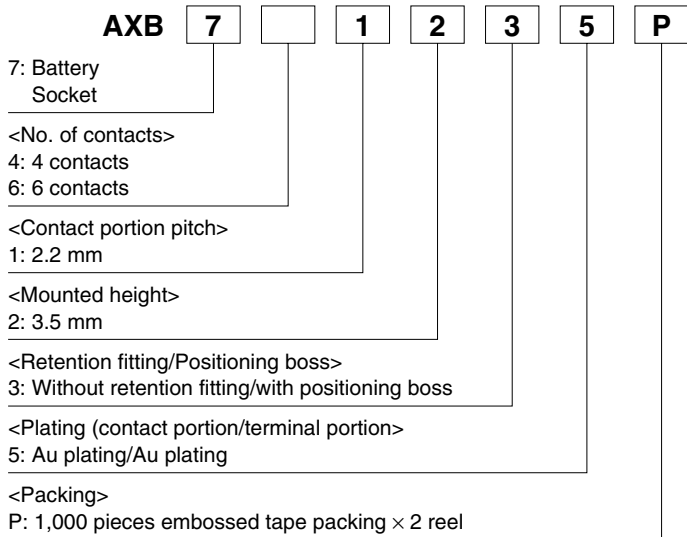

PRODUCT TYPES

No. of signal contacts	Terminal shape	Positioning boss	Part number	Packing quantity	
				Inner carton (1 reel)	Outer carton
4 contacts	SMD terminal	With positioning boss	AXB741235P	1, 000 pieces	2, 000 pieces
6 contacts			AXB761235P		

SPECIFICATIONS

1. Characteristics

Item	Specifications	Conditions	
Electrical characteristics	Rated current	2.0 A (Max. 6.0 A at total contacts)	
	Insulation resistance	Min. 1, 000 MΩ (initial)	Using 500 V DC megger (applied for 1 minute)
	Breakdown voltage	150 V AC for 1 minute	Detection current: 1mA
	Contact resistance	Max. 50 mΩ (initial)	Measured based on the HP4338B measurement method of JIS C 5402
Ambient temperature	-35 to +65°C		
Lifetime characteristics	5,000 times (battery insert and removal life)	Max. 200 times/hours	
Soldering heat resistance	Reflow soldering peak temperature: Max. 245°C	Surface temperature of connector	
Unit weight	AXB741235: 0.16 g, AXB761235: 0.23 g		

2. Material and surface treatment

Part name		Material	Surface treatment
Resin-molding portion	Body	PA resin	—
Metal portion	Contact	Copper alloy	Contact portion: Ni plating on base, Au plating on surface
			Terminal portion: Ni plating on base, Au plating on surface (except for thick of terminal)

DIMENSIONS (Unit: mm)

1. 4 contacts

AXB741235P

CAD Data



The CAD data of the products with a **CAD Data** mark can be downloaded from: <http://www.mew.co.jp/ac/e>

Recommended PC board pattern (TOP VIEW)

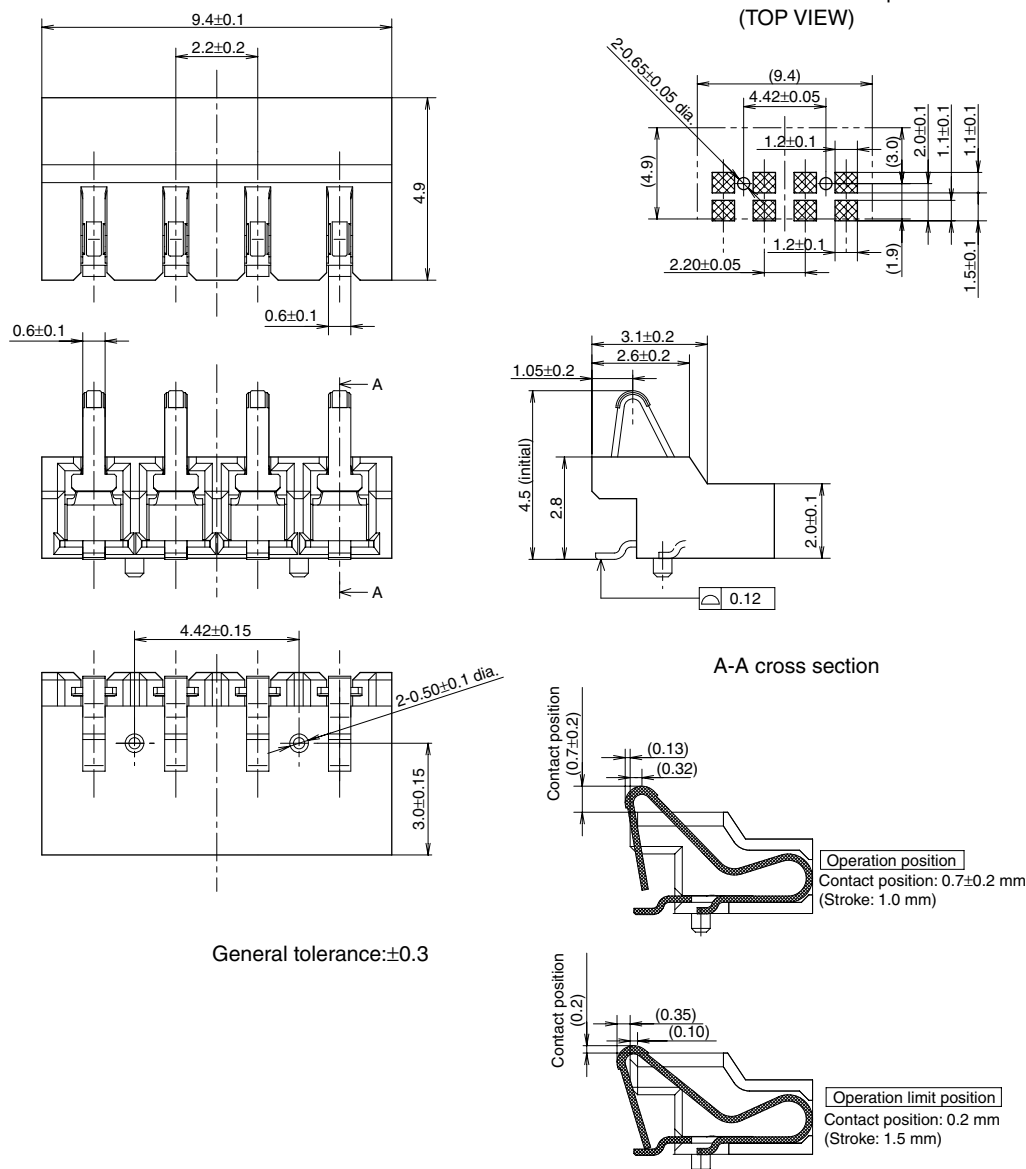

General tolerance: ±0.3

AXB7

2. 6 contacts
AXB761235P

CAD Data

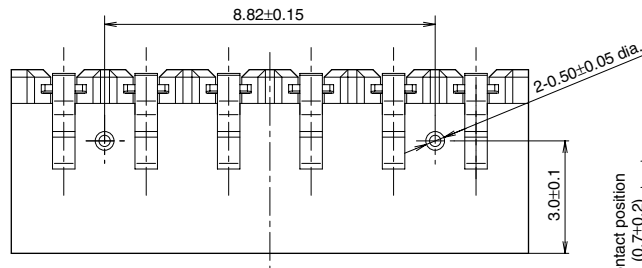
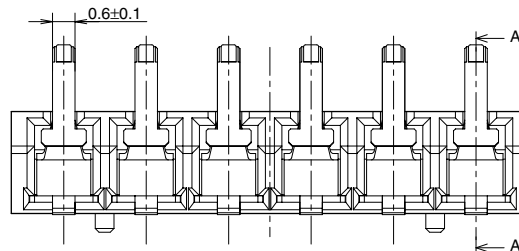
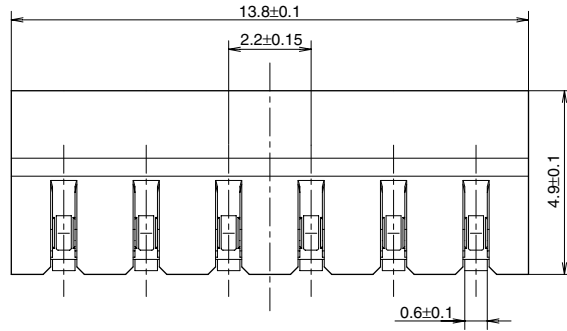

Recommended PC board pattern
(TOP VIEW)

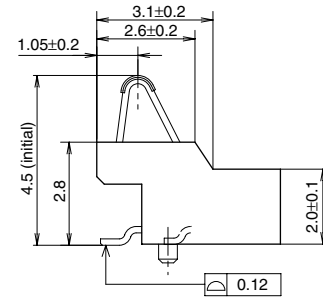
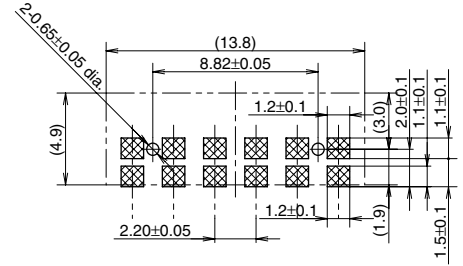

A-A cross section

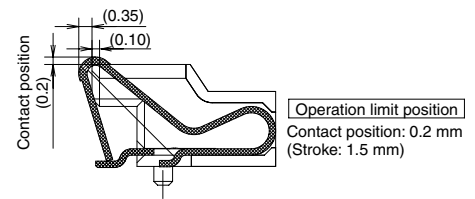
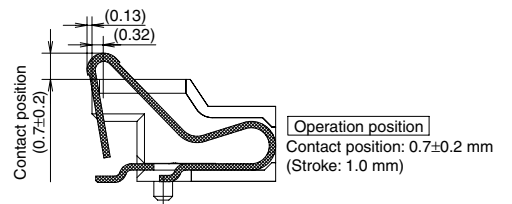

General tolerance:±0.3

EMBOSSED TAPE DIMENSIONS (mm)

• Tape dimensions (Conforming to JIS C 0806-1995)

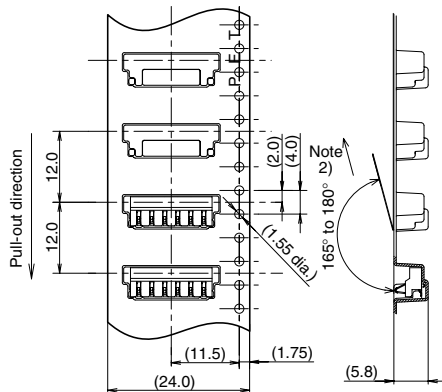

• Reel dimensions (Conforming to JIS C 0806-1995)

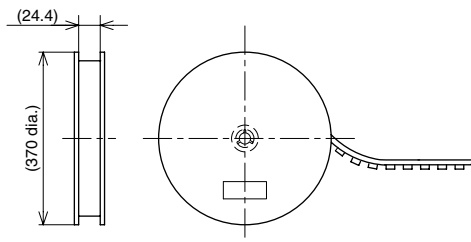

NOTES

For other details, please verify with the product specification sheets.