

New



FEATURES

1. Compatible with the Micro USB standards

Compatible with the new-generation USB connector standard, which was officially announced at the USB Implementers Forum in January 2007

2. Resistant to twisting

These connectors have two metal pegs added to the foot pattern recommended by the Micro USB connector standards to ensure secure fixing to PC boards. Also, the shell is made of stainless steel, and its seam has two dovetail joints, which provides higher resistance to the force applied for opening the seam.

3. Resistant to forcible insertion of a plug

The large crimped parts at the rear of the receptacle shell securely hold the receptacle body, providing high resistance to the forcible insertion of a plug.

4. Structure to prevent reverse insertion of a plug

The Micro USB standard requires that the AB type receptacle prevents plugs from being inserted in reverse orientation with a resin part in its mating section. The reinforced joint between our receptacle shell and body is also resistant to a plug's reverse insertion force.

APPLICATIONS

Interface portion of mobile phones and digital consumer products (e.g. DSC, DVC and Music players, etc.)

Compliance with RoHS Directive

ORDERING INFORMATION

AXJ 5 3 1 G

5: Micro USB connectors

<Receptacle>

3: Receptacle

<Composition>

3: Micro B right angle type

6: Micro AB right angle type

<Installation type, With/without the shell mating guide>

1: Standard type, with the shell mating guide

<Terminal shape, Pegs (retention fitting) shape and Positioning bosses>

2: Terminal portion: SMD, Pegs (retention fitting):

SMD and Positioning bosses: without positioning bosses

4: Terminal portion: SMD, Pegs (retention fitting):

DIP and Positioning bosses: without positioning bosses

<Package>

G: Embossed tape packaging

PRODUCT TYPES

Type		Terminal shape	Pegs (retention fitting)	Positioning bosses	Part number	Packing quantity	
						Inner carton (1 reel)	Outer carton (2 reels)
Receptacle	Micro B Right angle type	SMD terminal	SMD	Without positioning bosses	AXJ53312G	3,000 pcs.	6,000 pcs.
			DIP		AXJ53314G	2,500 pcs.	5,000 pcs.
	Micro AB Right angle type		SMD		AXJ53612G	3,000 pcs.	6,000 pcs.
			DIP		AXJ53614G	2,500 pcs.	5,000 pcs.

SPECIFICATIONS

1. Characteristics

Item	Specifications	Conditions	
Electrical characteristics	Rated current	When applying current only to signal terminals: 1.0 A (for terminal No. 2, 3 and 4) When applying current to the power terminal: 1.8 A (for terminal No. 1 and 5), 0.5 A (for terminal No. 2, 3 and 4)	
	Rated voltage	30V DC/AC	
	Contact resistance	Max. 30mΩ	EIA-364-23 (Inductive resistance to wire is not included)
	Insulation resistance	Min. 100MΩ	EIA-364-21 Using 100V DC megger
	Breakdown voltage	100V AC (Dielectric breakdown must not occur during a 1 min. application)	EIA-364-20 Detection current: 1mA
	Electrostatic capacity	Max. 2pF	EIA-364-30 (Measure it between the adjacent terminals of the unmated connector at a frequency of 1 kHz.)
Mechanical characteristics	Composite insertion force (initial)	Max. 35N EIA-364-13 Insert and remove a plug at a speed of 12.5 mm/min.	
Lifetime characteristics	Insertion and removal life	10,000 times Contact resistance: Max. 40 mΩ Composite insertion force: Max. 35N Composite removal force: Min. 8 N Appearance: No abnormality EIA-364-09 Repeated insertion and removal speed of max. 500 times/hours (Mechanical insertion and removal)	
Environmental characteristics	Ambient temperature	-55°C to 85°C	No freezing or condensation in low temperatures
	Storage temperature	-55°C to 85°C (-40°C to 50°C for packaging materials)	No freezing or condensation in low temperatures
	Vibration resistance	Discontinuity: Max. 1μs Contact resistance: Max. 40mΩ Appearance: No abnormality	EIA-364-28 Apply vibration in three directions including the mating axis that are perpendicular to one another for 15 minutes respectively with a 100 mA DC current applied. Cord length: 100mm Fix the cord end.
	Impact resistance	Discontinuity: Max. 1μs Contact resistance: Max. 40mΩ Appearance: No abnormality	EIA-364-27 Acceleration: 294m/s ² (30G) Duration: 11 ms, Application directions: 6 surfaces (X, Y, and Z directions) Number of applications: 3 times respectively (Total: 18 times) Cord length: 100mm Fix the cord end.
	Heat resistance (mated)	250 hours Contact resistance: Max. 40mΩ Breakdown voltage: 100V AC dielectric breakdown must not occur during a one-minute application. Insulation resistance: Min. 100MΩ Appearance: No abnormality	EIA-364-17 Temperature: 85±2°C
	Humidity resistance (mated)	7 cycles Contact resistance: Max. 40mΩ Breakdown voltage: 100V AC dielectric breakdown must not occur during a one-minute application. Insulation resistance: Min. 100MΩ Appearance: No abnormality	EIA-364-31 Method III
Soldering temperature resistance	Reflow soldering	Peak temperature: Max. 260°C	
	Manual soldering	300±10°C: Max. 5 s 350±10°C: Max. 3 s	

2. Material and surface treatment

Part name	Material	Surface treatment
Resin-molding portion	Heat-resistant resin (UL94V-0)	—
Metal parts	Contact	Copper alloy Contact portion: Ni plating on base, Au plating on surface Terminal portion: Ni plating on base, Au plating on surface (Except the cut ends)
	Shell	Stainless steel Ni plating on base, Sn plating on surface (Except the cut ends)

DIMENSIONS (unit: mm)

The CAD data of the products with a **CAD Data** mark can be downloaded from: <http://www.mew.co.jp/ac/e>

1. Micro B Receptacle

1) Pegs (retention fitting): SMD type

Part number
AXJ53312G

CAD Data



External dimensions

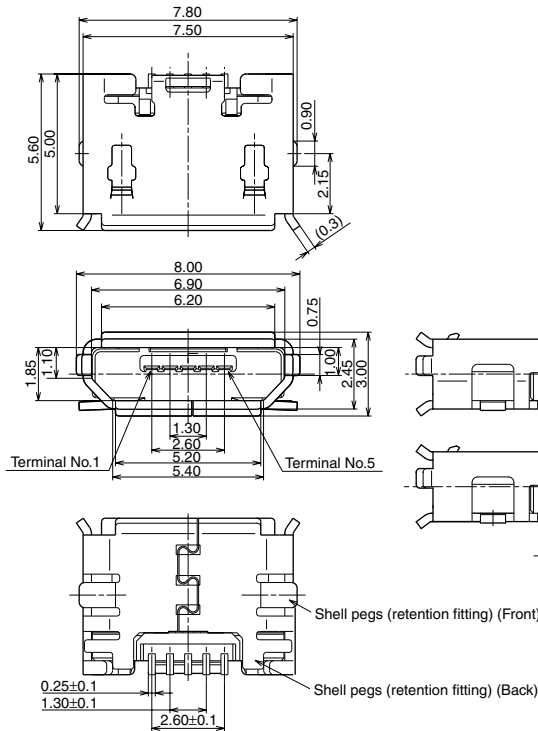

Recommended PC board pattern (TOP VIEW)

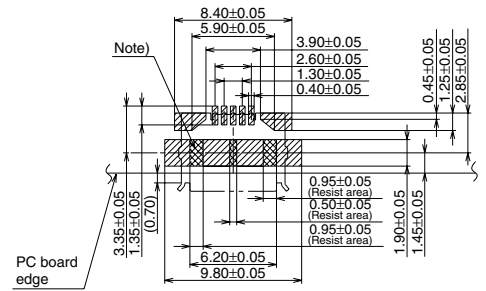

Note) : PC board pattern
 : Apply resist onto the PC board pattern.

When mounted on a PC board



General tolerance: ±0.3

2) Pegs (retention fitting): DIP type

Part number
AXJ53314G

CAD Data



External dimensions

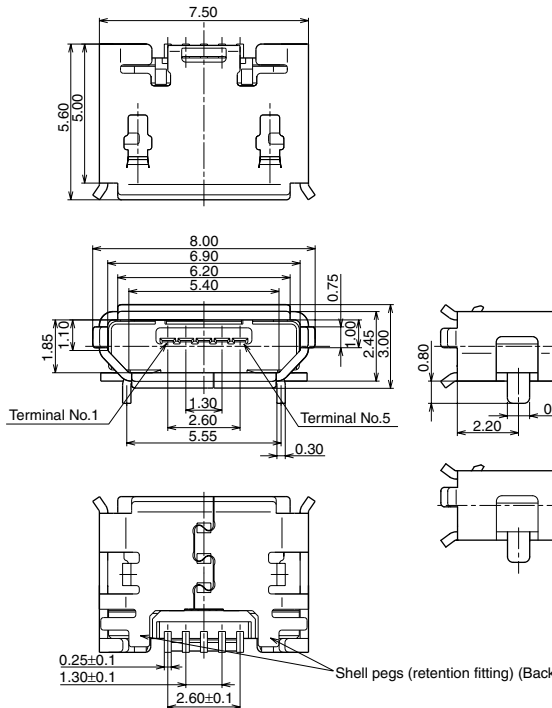

Recommended PC board pattern (TOP VIEW)

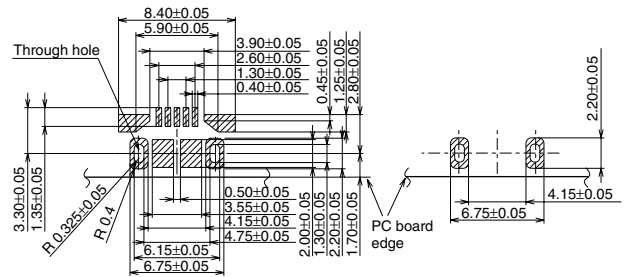

Top view

Bottom view

When mounted on a PC board

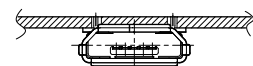

General tolerance: ±0.3

AXJ5

2. Micro AB Receptacle

1) Pegs (retention fitting): SMD type

Part number
AXJ53612G

CAD Data



External dimensions

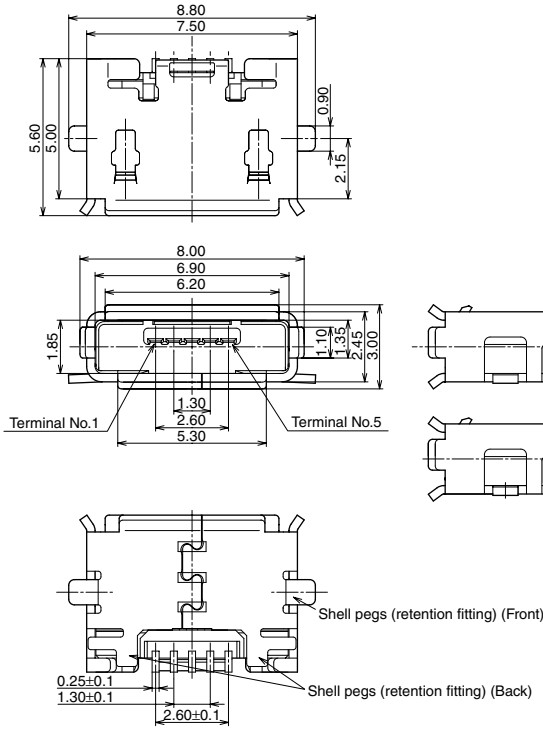

Recommended PC board pattern (TOP VIEW)

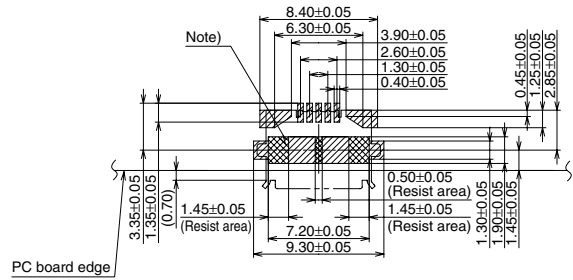

Note) : PC board pattern
 : Apply resist onto the PC board pattern.

When mounted on a PC board



General tolerance: ± 0.3

2) Pegs (retention fitting): DIP type

Part number
AXJ53614G

CAD Data



External dimensions

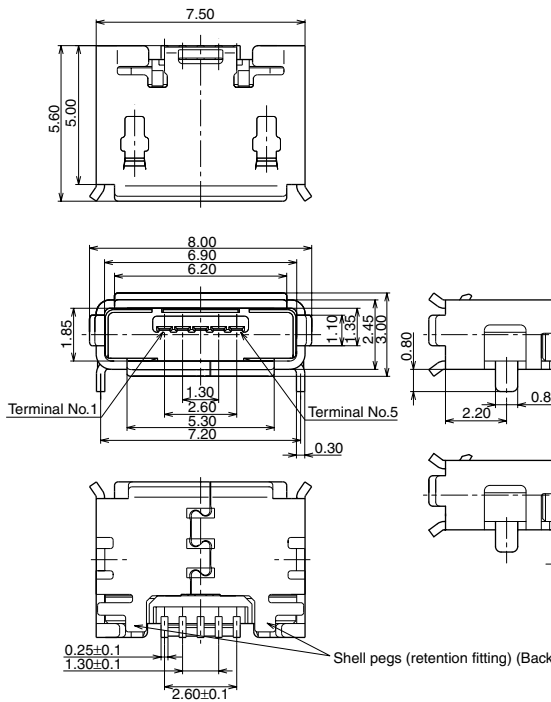

Recommended PC board pattern (TOP VIEW)

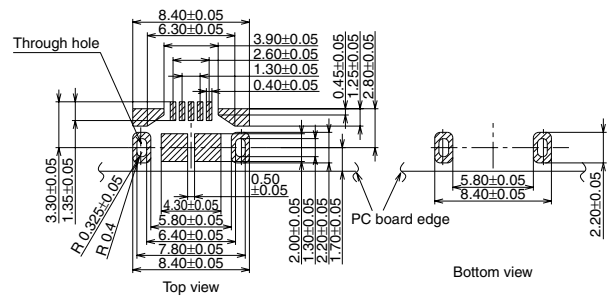

When mounted on a PC board

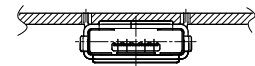

General tolerance: ± 0.3

EMBOSED TAPE DIMENSIONS (unit: mm)

• Tape dimensions (Conforming to JIS C 0806-3 1990)

• Reel dimensions (Conforming to EIAJ ET-7200B)

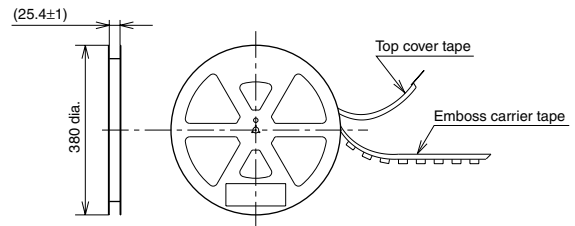
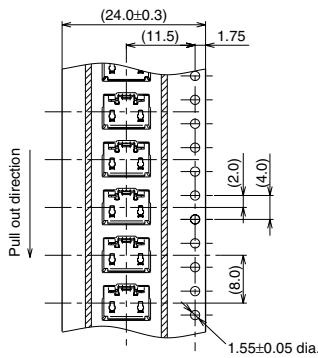

NOTES

1. Use of a cover is recommended when using this device in order to prevent scraps, dust, dirt, etc., from getting inside of the receptacle.

2. PC board design

Please refer to the recommended PC board pattern to ensure the strength of soldered portion of terminals.

3. Soldering

1) Manual soldering

- Please set up temperature and applied time of soldering iron as indicated in specification sheet.
- Avoid an excessive amount of solder from being applied, or it may flow into the shell.
- Please use soldering iron after confirming removal of dispersed solder flux on the contact surface by use of magnifying glass after each soldering.
- Do not apply a load to the terminals during soldering, or the contacts may be displaced.
- Please properly clean soldering iron.

2) Reflow soldering

- Screen printing is recommended for cream solder printing.
- Screen thickness of 0.12mm is recommended for cream solder printing.
- When applying different thickness of screen, please consult us.
- Depending upon size of connector, self alignments may not be expected. Please pay attention to align terminals and soldered pads.

• The following diagram shows the recommended reflow soldering temperature profile.

Recommended reflow soldering temperature profile

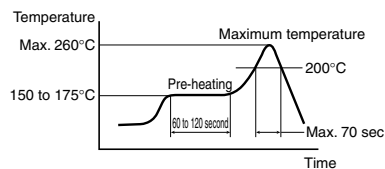

- The temperature measured on the PC board surface near connector terminals.
 - After reflow soldering, in case of PC board surface the reverse side using reflow soldering, for example an adhesive and so on connector of fixed disposition.
- ### 3) Rework of soldering portion
- Rework is one time.
 - Avoid an excessive amount of solder from being applied, or it may flow into the shell.
 - In case of soldering rework of bridges. Please use a flat-head soldering iron and don't use supplementary solder flux.
 - Please use the soldering iron under specification's temperature

4. Since excessive force on the terminals will cause deformation and the integrity of the soldering will be lost during reflow soldering, avoid dropping or rough handling of the product.

5. PC board warpage should be controlled less than 0.03mm to entire length of the connector.

6. Repeated bending of terminals and clips (retention fitting) can result in terminals breaking.

7. Regarding after soldering connectors on PC boards

- After mounting connectors on PC boards, do not apply excessive loads to the connector by piling up the boards.
- Please do not add the force to the connector during assembled connector on PC board.

8. This connector has metal shell for preventing EMI, when designing an enclosure the followings should be considered. Guide for plug entrance should be arranged in order to prevent distorted insertions. Provide a cover to reinforce the metal shell portions of the receptacle.

9. Others

To prevent insulation deterioration of PC board after soldering, please avoid adhesion coating agent to terminals in case of coating.

For other details, please verify with the product specification sheets.