

**NARROW-PITCH
CONNECTORS FOR
BOARD-TO-BOARD
CONNECTION**

**NARROW PITCH (0.6mm)
CONNECTORS P6 SERIES - P6S -**



Socket



Header

Compliance with RoHS Directive
<http://www.nais-e.com/>

FEATURES

1. Bellows-type contacts

Bellows-type contacts resist mating stress and offer high contact reliability.

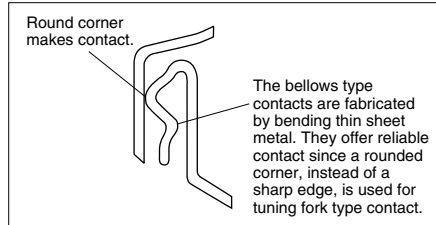

2. Porosity treatment applied for improved resistance against corrosion.

3. Mating length 1.1mm

The effective mating length has been extended to ensure that there is some latitude in the mating.

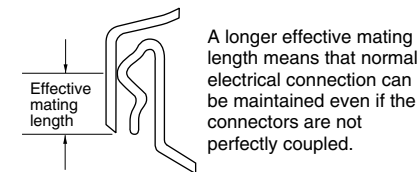

Type	Effective mating length
P6S	1.1mm

4. Automatic mounting

- 1) Suction area for suction-type automatic mounting machines is employed.
- 2) Embossed tape packaging is standard.
- 3) Terminal construction which is virtually resistant to solder bridging.

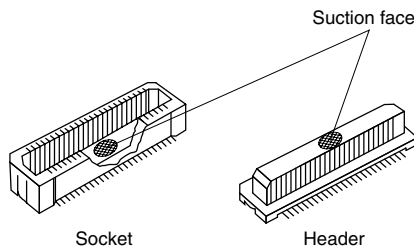

5. Compliance with RoHS' Directive

Environmentally friendly, the connectors' comply with Europe's RoHS' Directive. Cadmium, lead, mercury, hexavalent, chromium, PBB and PBDE are not used.

APPLICATIONS

1. Compact portable devices "Cellular phones, DVC, Digital cameras, etc"
2. This is ideal in applications involving information devices such as notebook computers, where connections are required between a backplane and a CPU board or another type of multi-wiring expansion board.

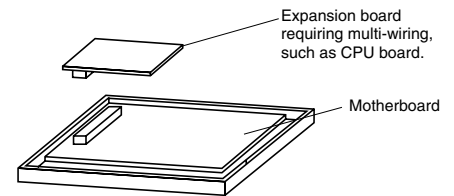

AXK(3/4)S

TABLE OF PRODUCT TYPES



Socket



Header

Mated height	4.0mm	5.0mm	6.0mm	7.0mm	8.0mm	9.0mm
	Number of contacts	20 ☆	☆	☆	☆	☆
	30 ☆	☆	☆	☆	☆	☆
	40 ☆	☆	☆	☆	☆	☆
	50 ☆	☆	☆	☆	☆	☆
	60 ☆	☆	☆	☆	☆	☆
	80 ☆	☆	☆	☆	☆	☆
	100 ☆	☆	☆	☆	☆	☆

- Notes: 1. Special orders are possible for contact numbers not listed in the table above.
(Please consult us in such a case.)
2. The standard type comes with positioning bosses. Connectors without positioning boss are available for on-demand production.

ORDERING INFORMATION

AXK **5** **G**

3S: Narrow Pitch Connector P6S (0.6 mm pitch) Socket
4S: Narrow Pitch Connector P6S (0.6 mm pitch) Header

Number of contacts (2 digits)

Mated height

<Socket>

0: For mated height 4.0 mm, 5.0 mm and 6.0 mm

3: For mated height 7.0 mm, 8.0 mm and 9.0 mm

<Header>

4: For mated height 4.0 mm and 7.0 mm

5: For mated height 5.0 mm and 8.0 mm

6: For mated height 6.0 mm and 9.0 mm

Functions

3: With positioning bosses

4: Without positioning bosses

Surface treatment (Contact portion / Terminal portion)

5: Ni plating on base, Au plating on surface / Ni plating on base, Au plating on surface

Packing

G: Socket for mated height 4.0, 5.0, 6.0 mm and header for mated height 4.0, 7.0 mm:

1,500 pieces embossed tape and plastic reel × 2

Socket for mated height 7.0, 8.0, 9.0 mm and header for mated height 5.0, 6.0, 8.0, 9.0 mm:

1,000 pieces embossed tape and plastic reel × 2

PRODUCT TYPES

Mated height	No. of contacts	Part No.		Packing	
		Socket	Header	Inner carton (1 reel)	Outer carton
4.0 mm	20	AXK3S20035G	AXK4S20435G	"G" mark on end of part No.; 1,500 pieces	"G" mark on end of part No.; 3,000 pieces
	30	AXK3S30035G	AXK4S30435G		
	40	AXK3S40035G	AXK4S40435G		
	50	AXK3S50035G	AXK4S50435G		
	60	AXK3S60035G	AXK4S60435G		
	80	AXK3S80035G	AXK4S80435G		
5.0 mm	100	AXK3S00035G	AXK4S00435G	"G" mark on end of part No.; Socket: 1,500 pieces Header: 1,000 pieces	"G" mark on end of part No.; Socket: 3,000 pieces Header: 2,000 pieces
	20	AXK3S20035G	AXK4S20535G		
	30	AXK3S30035G	AXK4S30535G		
	40	AXK3S40035G	AXK4S40535G		
	50	AXK3S50035G	AXK4S50535G		
	60	AXK3S60035G	AXK4S60535G		
6.0 mm	80	AXK3S80035G	AXK4S80535G	"G" mark on end of part No.; Socket: 1,000 pieces Header: 1,500 pieces	"G" mark on end of part No.; Socket: 2,000 pieces Header: 3,000 pieces
	100	AXK3S00035G	AXK4S00535G		
	20	AXK3S20035G	AXK4S20635G		
	30	AXK3S30035G	AXK4S30635G		
	40	AXK3S40035G	AXK4S40635G		
	50	AXK3S50035G	AXK4S50635G		
7.0 mm	60	AXK3S60035G	AXK4S60635G	"G" mark on end of part No.; Socket: 1,000 pieces Header: 1,500 pieces	"G" mark on end of part No.; Socket: 2,000 pieces Header: 3,000 pieces
	80	AXK3S80035G	AXK4S80635G		
	100	AXK3S00035G	AXK4S00635G		
	20	AXK3S20335G	AXK4S20435G		
	30	AXK3S30335G	AXK4S30435G		
	40	AXK3S40335G	AXK4S40435G		
8.0 mm	50	AXK3S50335G	AXK4S50435G	"G" mark on end of part No.; 1,000 pieces	"G" mark on end of part No.; 2,000 pieces
	60	AXK3S60335G	AXK4S60535G		
	80	AXK3S80335G	AXK4S80535G		
	100	AXK3S00335G	AXK4S00535G		
	20	AXK3S20335G	AXK4S20635G		
	30	AXK3S30335G	AXK4S30635G		
9.0 mm	40	AXK3S40335G	AXK4S40635G	"G" mark on end of part No.; 1,000 pieces	"G" mark on end of part No.; 2,000 pieces
	50	AXK3S50335G	AXK4S50635G		
	60	AXK3S60335G	AXK4S60635G		
	80	AXK3S80335G	AXK4S80635G		
	100	AXK3S00335G	AXK4S00635G		
	20	AXK3S20335G	AXK4S20635G		

Notes) 1. Regarding ordering units: During production: Please make orders in 1 reel units.

Samples for mounting confirmation: Available in units of 50 pieces. Please consult us. (See "Regarding sample orders to confirm proper mounting" on page 13.)

Samples: Small lot orders are possible.

2. The standard type comes without positioning bosses. Connectors with positioning bosses are available for on-demand production.

For this type of connector, 9th digit of the part no. changes from 3 to 4 e.g. Mated height 4.0 mm, 20 contacts for sockets: AXK3S20045G.

AXK(3/4)S

SPECIFICATIONS

1. Characteristics

Item	Specifications		Conditions
	Mated height: 4.0mm, 5.0mm, 6.0mm, 7.0mm, 8.0mm, 9.0mm		
Electrical characteristics	Rated current	0.5A/terminal (Max. 16 A)	
	Rated voltage	60V AC/DC	
	Breakdown voltage	150V AC for 1 min.	Detection current: 1mA
	Insulation resistance	Min. 1,000M Ω	Using 500V DC megger
	Contact resistance	Max. 80m Ω	Measured based on the HP4338B measurement method of JIS C 5402
Mechanical characteristics	Composite insertion force	Max. 0.785N {80gf} \times no. of contacts (initial)	
	Composite removal force	Min. 0.0588N {6gf} \times no. of contacts	
	Post holding force	Min. 0.98N {100gf}	Measures the maximum load in the post axial direction until removal
Environmental characteristics	Ambient temperature	-55°C to +85°C	No freezing at low temperatures
	Soldering heat resistance	Max. peak temperature of 245°C	Infrared reflow soldering
		300°C within 5 sec.	Soldering iron
	Thermal shock resistance (header and socket mated)	5 cycles, insulation resistance min. 100M Ω , contact resistance max. 80m Ω	Sequence 1. -55 $\frac{-3}{0}$ °C, 30 minutes 2. ~, Max. 5 minutes 3. 85 $\frac{+3}{0}$ °C, 30 minutes 4. ~, Max. 5 minutes
	Humidity resistance (header and socket mated)	120 hours, insulation resistance min. 100M Ω , contact resistance max. 80m Ω	Bath temperature 40 \pm 2°C, humidity 90 to 95% R.H.
	Saltwater spray resistance (header and socket mated)	24 hours, insulation resistance min. 100M Ω , contact resistance max. 80m Ω	Bath temperature 35 \pm 2°C, saltwater concentration 5 \pm 1%
Lifetime characteristics	H ₂ S resistance (header and socket mated)	48 hours, contact resistance max. 80m Ω	Bath temperature 40 \pm 2°C, gas concentration 3 \pm 1 ppm, humidity 75 to 80% R.H.
		Insertion and removal life	50 times
Unit weight	P6S Mated height: 4mm 50 contacts; Socket: 0.29g Header: 0.26g		

2. Material and surface treatment

Part name	Mated height: 4.0mm, 5.0mm, 6.0mm, 7.0mm, 8.0mm, 9.0mm	
	Material	Surface treatment
Molded portion	Heat-resistant resin (UL94V-0)	—
Contact/post	Copper alloy	Contact portion: Ni plating on base, Au plating on surface Terminal portion: Ni plating on base, Au plating on surface (Except for thick of terminal)

DIMENSIONS

mm General tolerance: \pm 0.2

• Mated height: 4.0mm, 5.0mm, 6.0mm, 7.0mm, 8.0mm, 9.0mm

• Socket

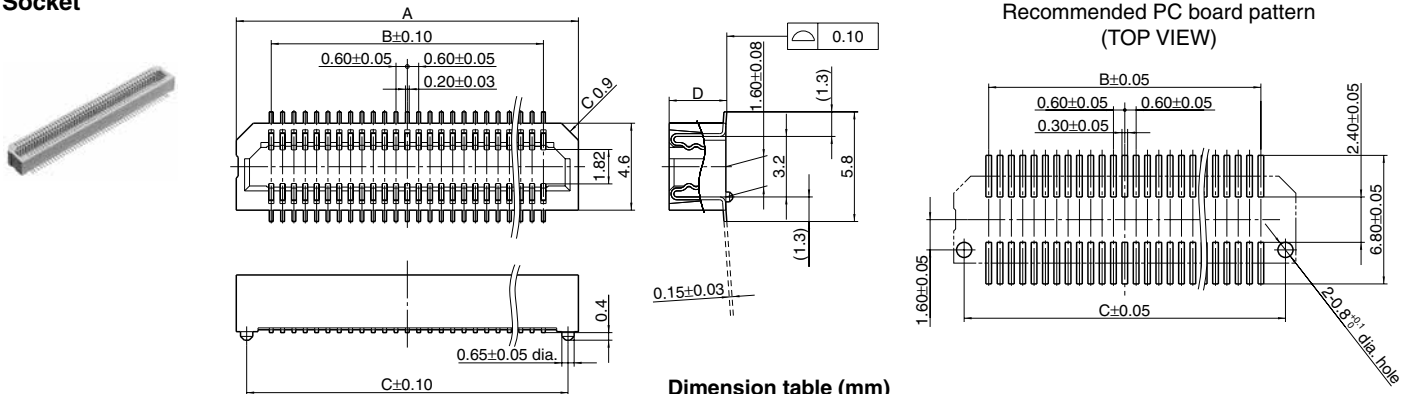

Dimension table (mm)

No. of contact	A	B	C	Mated height	D
20	9.1	5.40	8.00	4.0mm, 5.0mm, 6.0mm	3.05
30	12.1	8.40	11.00	7.0mm, 8.0mm, 9.0mm	6.05
40	15.1	11.40	14.00		
50	18.1	14.40	17.00		
60	21.1	17.40	20.00		
80	27.1	23.40	26.00		
100	33.1	29.40	32.00		

• Header

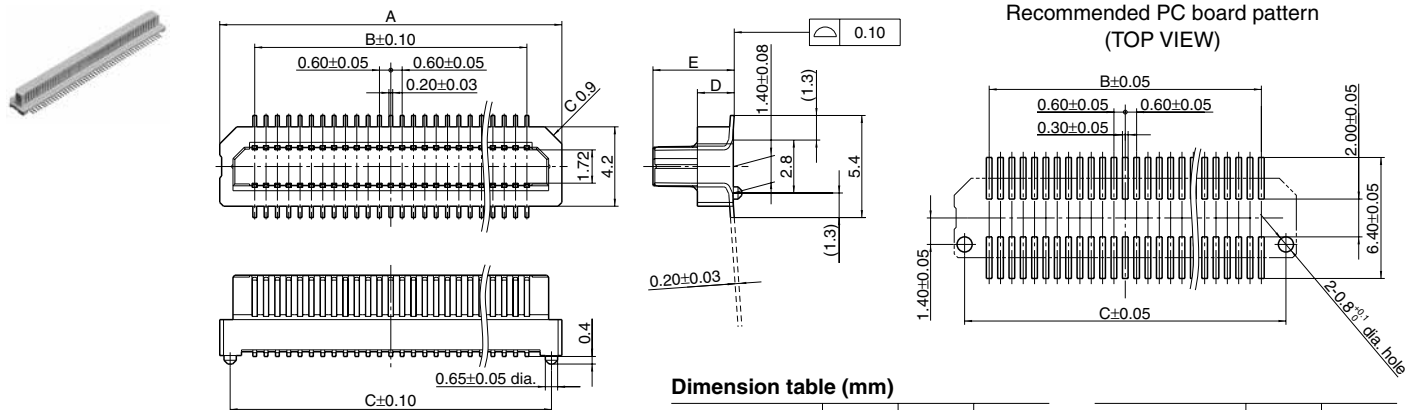

Dimension table (mm)

No. of contact	A	B	C
20	9.1	5.40	8.00
30	12.1	8.40	11.00
40	15.1	11.40	14.00
50	18.1	14.40	17.00
60	21.1	17.40	20.00
80	27.1	23.40	26.00
100	33.1	29.40	32.00

Mated height	D	E
4.0mm, 7.0mm	0.95	3.3
5.0mm, 8.0mm	1.95	4.3
6.0mm, 9.0mm	2.95	5.3

Socket and header are mated



Mated height	H
4.0mm	4
5.0mm	5
6.0mm	6
7.0mm	7
8.0mm	8
9.0mm	9

EMBOSSED TAPE DIMENSIONS (unit:mm, Common for respective contact type, socket and header)

• Tape dimensions (Conforming to JIS C 0806-1990.)

• Plastic reel dimensions (Conforming to EIAJ ET-7200B)

However, some tapes have mounting hole pitches that do not comply with the standard.)

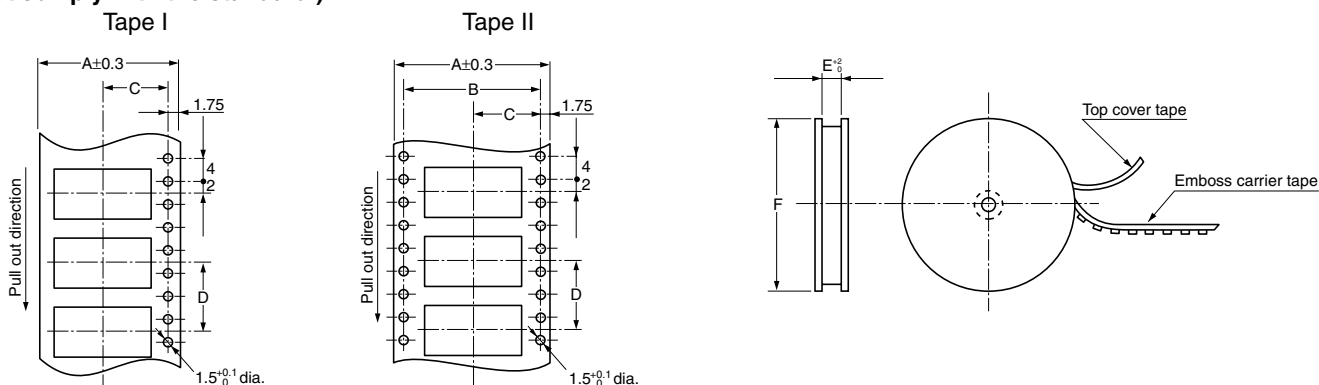

AXK(3/4)S

Dimension table (mm)

Suffix: G (embossed tape package)

Mated height	No. of contacts	Type of taping	A	B	C	D	E	F	Quantity per reel
Socket: 4.0mm, 5.0mm, 6.0mm	20 to 40	Tape I	24.0	—	11.5	12.0	25.4±1	380 dia.	1,500
	50 to 60	Tape II	32.0	28.4	14.2	12.0	33.4±1	380 dia.	
	80	Tape II	44.0	40.4	20.2	12.0	45.4±1	380 dia.	
	100	Tape II	56.0	52.4	26.2	12.0	57.4±1	380 dia.	
Socket: 7.0mm, 8.0mm, 9.0mm	20 to 40	Tape I	24.0	—	11.5	12.0	25.4±1	380 dia.	1,000
	50 to 60	Tape II	32.0	28.4	14.2	12.0	33.4±1	380 dia.	
	80	Tape II	44.0	40.4	20.2	12.0	45.4±1	380 dia.	
	100	Tape II	56.0	52.4	26.2	12.0	57.4±1	380 dia.	
Header: 4.0mm, 7.0mm	20 to 40	Tape I	24.0	—	11.5	12.0	25.4±1	380 dia.	1,500
	50	Tape II	32.0	28.4	14.2	12.0	33.4±1	380 dia.	
	60 to 80	Tape II	44.0	40.4	20.2	12.0	45.4±1	380 dia.	
	100	Tape II	56.0	52.4	26.2	12.0	57.4±1	380 dia.	
Header: 5.0mm, 6.0mm, 8.0mm, 9.0mm	20 to 40	Tape I	24.0	—	11.5	12.0	25.4±1	380 dia.	1,000
	50 to 60	Tape II	32.0	28.4	14.2	12.0	33.4±1	380 dia.	
	80	Tape II	44.0	40.4	20.2	12.0	45.4±1	380 dia.	
	100	Tape II	56.0	52.4	26.2	12.0	57.4±1	380 dia.	

Connector orientation with respect to direction of progress of embossed tape

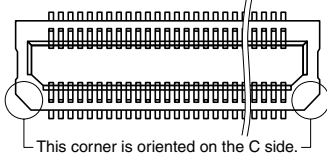
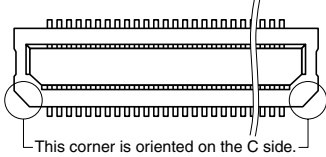
Direction of tape progress	Type	Common for P6S	
	Socket	Header	
			

NOTES

1. Prevention of reverse mating

Excessive mating force may damage the key, so be sure to match chamfered corners when mating.

Regarding general notes, please refer to page 12.

For other details, please verify with the product specification sheets.

Outline (top view)

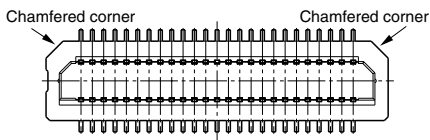
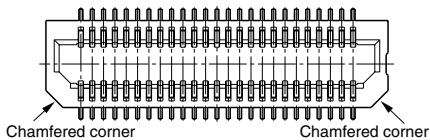

Mating state

