

1.78-mm thick sockets with superior robustness and EMI resistance achieved by the double-sided metal shell
Low-profile high-reliability socket

SOCKET FOR
microSD™ CARD

FEATURES

1. The double-sided metal shell and laser welding provides superior robustness and EMI resistance.

When a card is inserted, both sides of the card are covered with the metal shield, which offers superior EMI resistance. The shell also allows for more robust design than that with the single-sided resin-molded shell, reducing effects of the reflow heat.

2. The twin contact power terminals offer superior contact reliability.

Compared to single contact terminals, the twin contact structure used in the power terminals reduces the possibility of sudden power cut-down.

3. The PCB cut-off reverse type has achieved the ultra-low height from the board surface of 0.83 mm. Contributes to the reduction of the target equipment's thickness.

* Possible only with the PCB cut-off reverse type.

The PCB cut-off reverse type is the type in which the socket fits into an area cut out from the PC board. Including the PC board, the reduced overall thickness allows for the lowest possible profile.

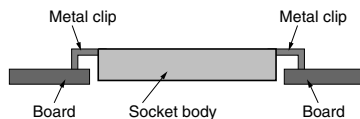

4. The detection accuracy shall not be affected by the card thickness.

The detection switch detects a card in the card insertion direction.

Highly reliable detection is possible regardless of variations in card dimension, material, and manufacturing method. (NC contact)

5. Jump-out protection mechanisms

6. Fully compatible with T-Flash card

New



On board mounting standard type



PCB cut-off reverse type



On board mounting reverse type

Compliance with RoHS Directive

What's a microSD™ card?

The microSD™ card is an ultra-miniature memory card that is completely compatible with the TransFlash card, which is increasingly adopted mainly by mobile phones. The microSD™ card is a new-generation memory card certified by the SD Card Association, which is an organization for standardizing SD cards, in July 2005 as a successor to the TransFlash card.

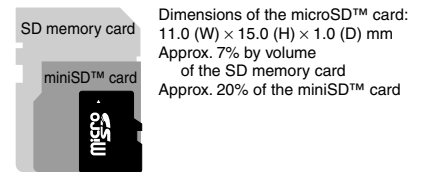

Dimensions of the microSD™ card:
11.0 (W) × 15.0 (H) × 1.0 (D) mm
Approx. 7% by volume of the SD memory card
Approx. 20% of the miniSD™ card

APPLICATIONS

Mobile phones, etc. that uses microSD™ card.

Mobile phones and compact portable devices, etc.



ORDERING INFORMATION

AXA 4 [] 3 [] [] [] [] P

4: Sockets for microSD™ card

<Board mounting direction>

6: Reverse type (outside terminal)

7: Standard type (outside terminal)

<Eject type>

3: Push-push type

<Stand off height>

0: Not available (0.05 mm)

7: -0.95 mm (for PCB cut-off type)

<Function>

(Card jump-out prevention function/Card presence detection switch/RF terminal)

	Card jump-out prevention function	Card presence detection switch	RF terminal
5	Available	Available	Available
6	Available	Available	Not available

<Terminal/Retention fitting/Positioning boss>

	Signal terminal	Retention fitting	Positioning bosses
1	SMD	SMD	With positioning bosses
2	SMD	SMD	Without positioning bosses
4	SMD	DIP	Without positioning bosses

<Packing>

P: Embossed tape

PRODUCT TYPES

Product name	Eject type	Card detection	Card jump-out prevention function	Positioning bosses	RF terminal	Mounting type	Part No.	Packing quantity	
								Inner carton	Outer carton
Sockets for microSD™ card	Push-push type	Available	Available	With positioning bosses	Not available	On board mounting standard type	AXA473061P	1,000 pieces (1 reel)	2,000 pieces (2 reels)
				Without positioning bosses			AXA473062P		
				—	Available	PCB cut-off reverse type	AXA463754P		
				—	Not available		AXA463764P		
				With positioning bosses	Available	On board mounting reverse type	AXA463051P		
				Without positioning bosses			AXA463052P		
				With positioning bosses	Not available	On board mounting reverse type	AXA463061P		
				Without positioning bosses			AXA463062P		

SPECIFICATIONS

1. Characteristics (Performance when microSD™ card is mated. Based on microSD™ card specification Ver. 1.0.)

	Item	Specifications	Condition
Electrical characteristics	Rated voltage	3.6V DC	
	Rated current	0.5A DC/1 terminal	
	Contact resistance	Signal contact portion: Max. 100mΩ Detection contact portion: Max. 500mΩ	Measured based on the HP4338B measurement method of JIS C 5402
	Insulation resistance	Min. 1,000MΩ	Using 500V DC megger (applied for 1 min.)
	Breakdown voltage	500V AC for 1 min.	Rated voltage is applied for one minute and check for short circuit or damage with a detection current of 1 mA.
Mechanical characteristics	Vibration resistance	Frequency: 10 to 55 Hz Acceleration: 20.0 m/s ² {2.0G} No current interruption for more than 0.1 μs	
	Card locking force	Max. 40N {4.08kgf}	
Lifetime characteristics	Insertion and removal life of card	Mechanical life: 10,000 times After testing: Contact resistance: Max. 40mΩ (Change from the initial value) Insulation resistance: Max. 100MΩ	Insertion and removal speed are at a rate of 500 times/hour or less.
Environment characteristics	Ambient temperature	-25°C to +85°C	No freezing or condensation in low temperatures
	Storage temperature	-40°C to +85°C (The allowable storage temperature is -40°C to +50°C if unopened from original packaging)	No freezing or condensation in low temperatures
	Resistance to soldering heat	Reflow soldering: peak temperature 260°C or less Manual soldering: soldering iron tip temperature 300°C, 5 sec. or less	Sockets (shell) surface temperature for using infrared reflow soldering machine
Applicable memory card		microSD™ card (based on specification Ver. 1.10) and Trans Flash card	
Unit weight		0.65g	

(AXA4)

2. Material and surface treatment

Portion	Material	Surface
Signal contact	Copper alloy	Contact portion: Ni plating on base, PdNi plating + Au flash plating on surface Soldering portion: Ni plating on base, Au plating on surface
Detection contact	Copper alloy	Contact portion: Ni plating on base, PdNi plating on surface Soldering portion: Ni plating on base, Au plating on surface
Retention fittings	Stainless steel	Soldering portion: Au + Pd plating on surface

DIMENSIONS (Unit: mm)

The CAD data of the products with a **CAD Data** mark can be downloaded from: <http://www.mew.co.jp/ac/e>

1. On board mounting standard type (outside terminal) Without RF terminal

Part No.

AXA473061P (With positioning bosses)

AXA473062P (Without positioning bosses)

CAD Data

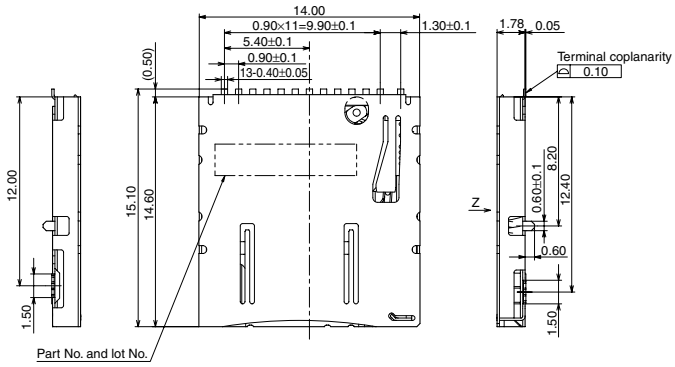

Part No. and lot No.

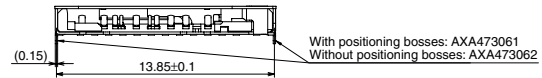

Tolerance: ± 0.2
unless otherwise specified

Card detection switch contact condition chart

Card attachment condition	Card detection switch
Card not attached	Closed
Card attached	Open
Terminal number	(A)-(B)

Pin arrangement

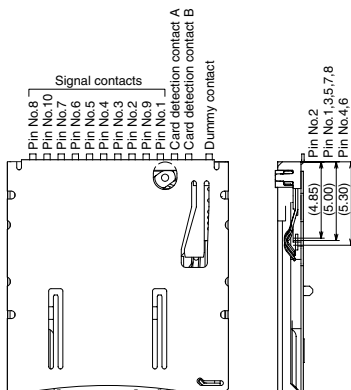

* Pins No. 9 and 10 are dummy contacts.

View of set card

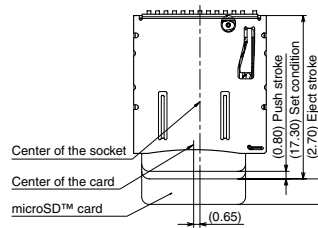

Pattern insulation is recommended (The sockets have a double-sided metal shell. When locating a wiring pattern beneath a socket, ensure adequate insulation of the pattern.)

Recommended PC board pattern (TOP VIEW)

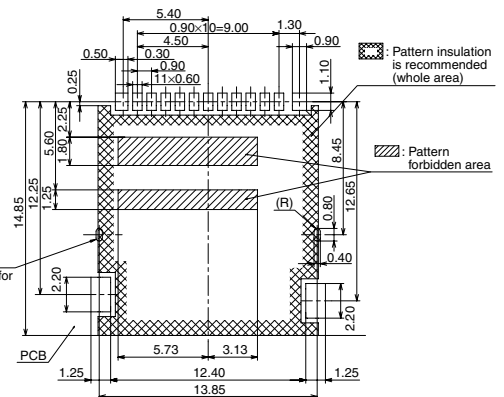

Dimensional tolerance of PC boards: ± 0.05

(AXA4)

4. On board mounting reverse type (outside terminal) With RF terminal

Part No.

AXA463051P (With positioning bosses)

AXA463052P (Without positioning bosses)

CAD Data



Card detection switch contact condition chart

Card attachment condition	Card detection switch
Card not attached	Closed
Card attached	Open
Terminal number	(A)-(B)

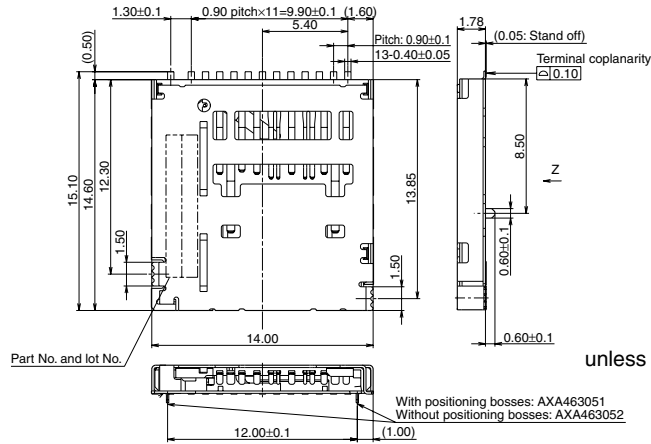

Tolerance: ±0.2
unless otherwise specified

Pin arrangement

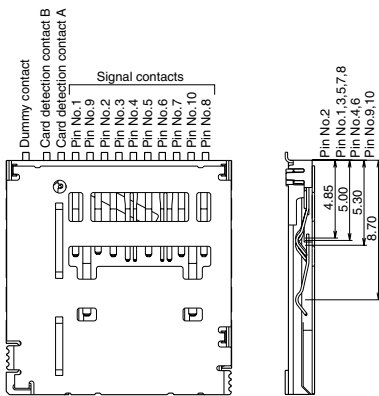

View of set card

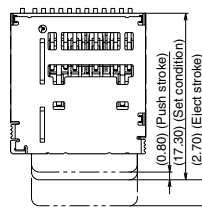

Pattern insulation is recommended
(The sockets have a double-sided metal shell.
When locating a wiring pattern beneath a socket,
ensure adequate insulation of the pattern.)

Recommended PC board pattern (TOP VIEW)

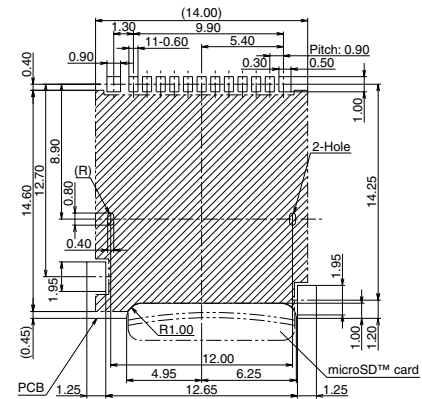

Dimensional tolerance of PC boards: ±0.05

5. On board mounting reverse type (outside terminal) Without RF terminal

Part No.

AXA463061P (With positioning bosses)

AXA463062P (Without positioning bosses)

CAD Data



Card detection switch contact condition chart

Card attachment condition	Card detection switch
Card not attached	Closed
Card attached	Open
Terminal number	(A)-(B)

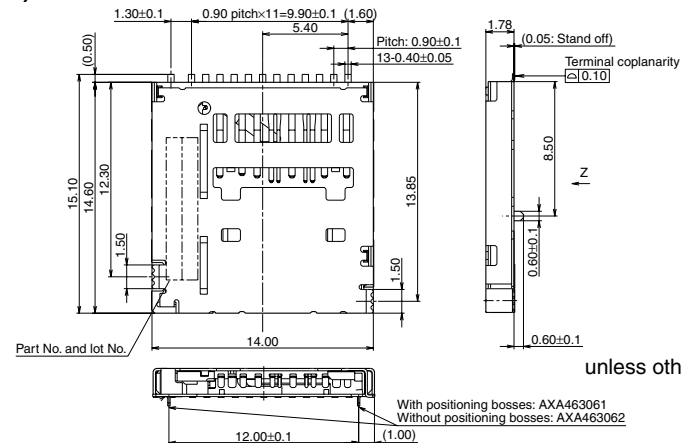

Tolerance: ±0.2
unless otherwise specified

Pin arrangement

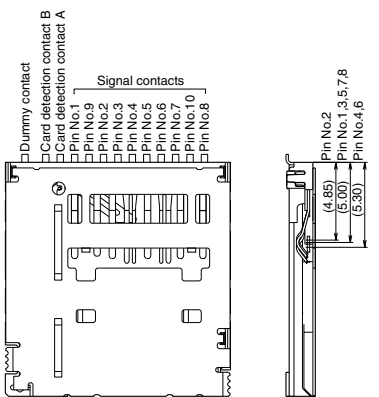

* Pins No. 9 and 10 are dummy contacts.

View of set card

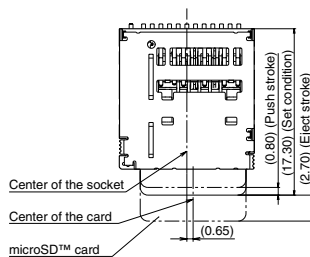

Pattern insulation is recommended
(The sockets have a double-sided metal shell.
When locating a wiring pattern beneath a socket,
ensure adequate insulation of the pattern.)

Recommended PC board pattern (TOP VIEW)

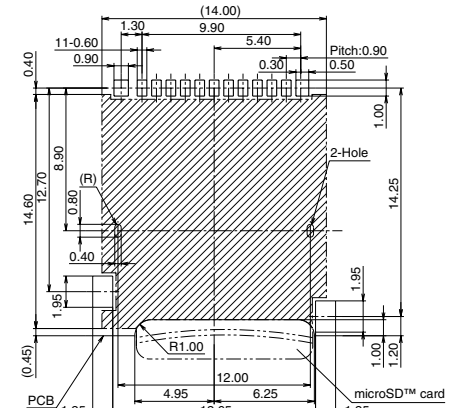

Dimensional tolerance of PC boards: ±0.05

EMBOSSED TAPE AND REEL (Unit: mm)

• Tape dimensions

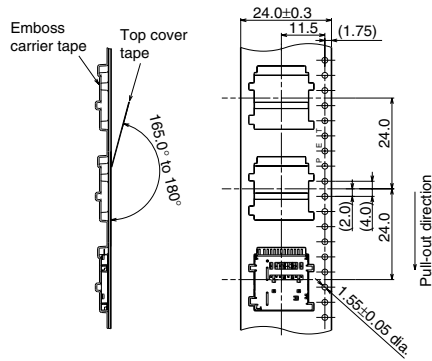

• Reel dimensions (Conforming to EIAJ ET-7200B)

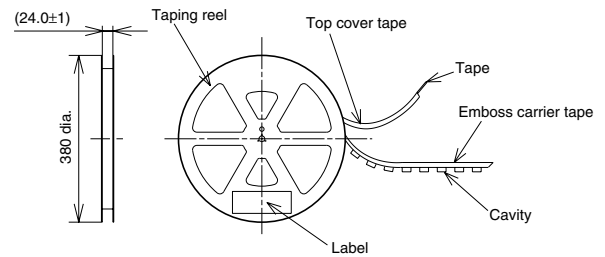
**NOTES****1. Regarding the design of PC board patterns**

Conduct the recommended foot pattern design, in order to preserve the mechanical strength of terminal solder areas.

2. Regarding the socket mounting

1) When reflow soldering when the slider is locked, heat will cause the slider to deform and not work. Therefore, please confirm that the slider lock is released before mounting if you have inserted and removed a card before soldering.

2) Be aware that during mounting, external forces may be applied to the connector contact surfaces and terminals and cause deformations.

3. Soldering

1) Reflow soldering

- Screen-printing method is recommended for cream solder printing.
- Use the recommended foot pattern for cream solder printing (screen thickness: 0.12 mm).
- When applying the different thickness of a screen, please consult us.
- Use the recommended reflow temperature profile conditions shown on the below.

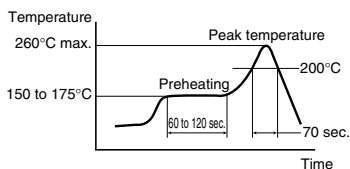
Recommended reflow temperature profile conditions

- The temperature must be measured on the surface of the PC board around the connector terminals.

2) Hand soldering

Set the soldering tip to 300°C, and solder for no more than 5 seconds.

4. Cleaning after soldering

Inside the socket there is a slider section and card detection contact/write protection mechanism. If anything such as flux remains inside after washing, insertion and removal will be hampered and contact will be faulty. Therefore, do not use methods that involve submersion when cleaning. (Partial cleaning of the PCB and soldered terminals is possible.)

5. After PC board mounting

- 1) Warping of the PC board should be no more than 0.03 mm for the entire connector length.
- 2) When assembling PCBs or storing them in block assemblies, make sure that undue weight is not exerted on a stacked socket.
- 3) Be sure not to allow external pressure to act on sockets when assembling PCBs or moving in block assemblies.

6. Handling single components

- 1) Make sure not to drop or allow parts to fall from work bench
- 2) Be cautious when handling because excessive force applied to the terminals will cause deformation and loss of terminal coplanarity.
- 3) Repeated bending of the terminals may break them.

7. Card fitting

- 1) The socket's molded part is partly thinned to achieve the smaller and lighter design. Therefore, carefully design the target device's housing to prevent the excessively twisted card insertion/removal and insertion in a slanted direction.
- 2) The sockets are constructed to prevent reverse card insertion. Caution is required because repeated, mistaken reverse insertion may damage the socket and card.

3) When not soldered, be careful not to insert and remove the socket's card.

Doing so will cause a decrease in anchoring ability of the mated part and loss of coplanarity.

4) Forcibly removing a fitted card may degrade the card removal prevention lock. To remove a card, be sure to push the card in the insertion direction to release the lock before pulling out the card.

8. Device design

1) Contact failure may result if dust or dirt enters the contact section. Please take appropriate measures when designing the device to prevent this from happening, for example by adding a cover.

2) To ensure smooth insertion and removal of cards, please design the chassis so that no force is applied to the metal shell on top of the socket. If a force is present that pushes down on the metal shell, the card will be pressed, which might prevent ejection.

3) Please provide a guide or similar to keep the socket from having force applied to it when inserting and removing.

9. Others

If you coat the PCB after soldering for insulation and to prevent wear, make sure that the coating does not adhere to the socket.

For other details, please verify with the product specification sheets.